

K A

T +

E

The Orion logo features the word "ORION" in a bold, white, sans-serif font. A light gray, stylized orbital ring or path is superimposed over the letters, starting from the top of the 'O' and curving around the 'I' and 'O'.

ORION

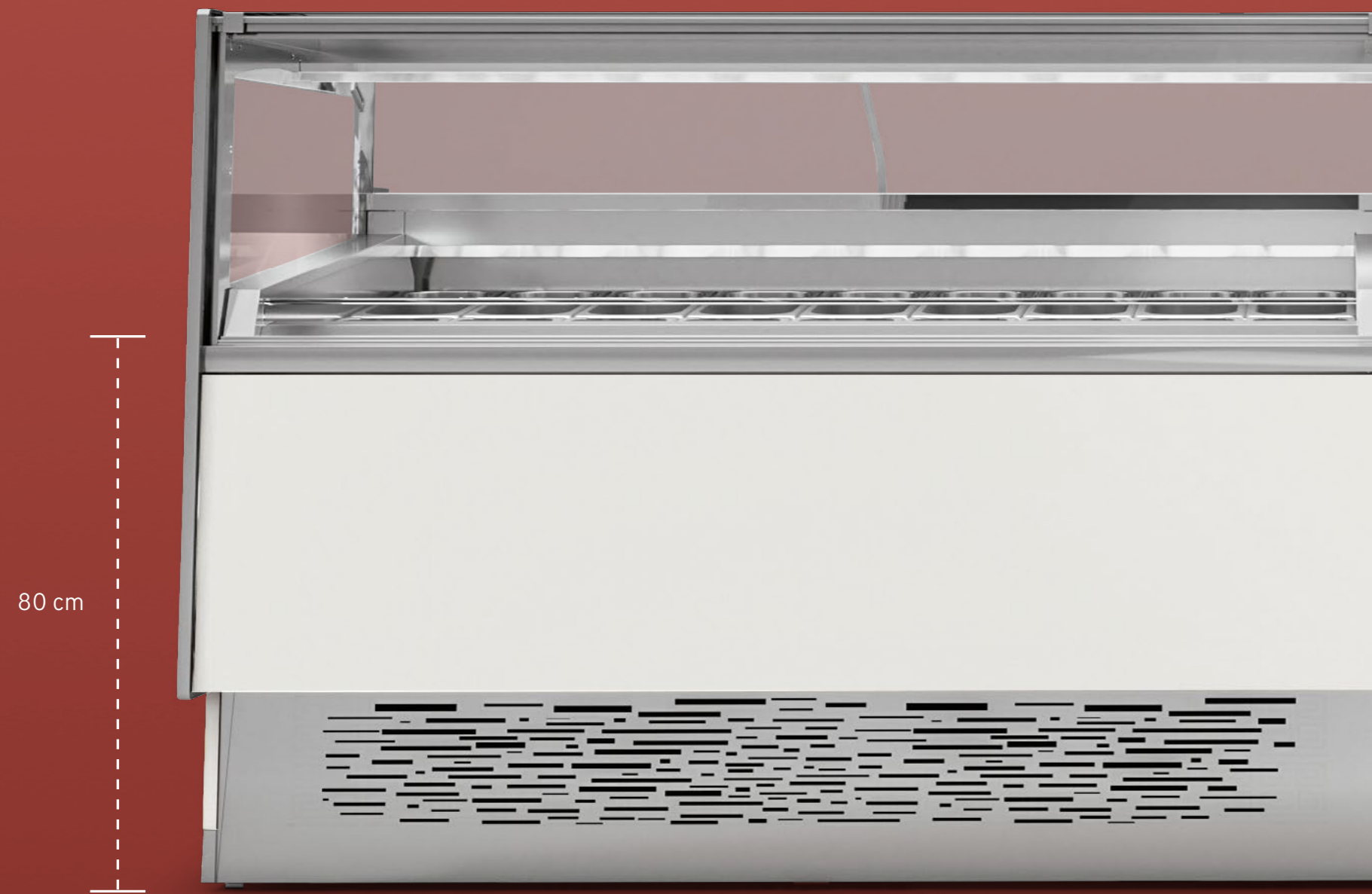

K A
T +
E
KATE
PLUS

**Molto di più
di una semplice
vetrina gelato.**

Much more than an ice cream cabinet.

Grazie al suo nuovo
design Kate+ è la prima
vetrina del suo segmento
che garantisce la massima
visibilità del gelato
già a 80 cm da terra.

Thanks to its new design Kate+
is the first showcase of its segment
which guarantees maximum
visibility of the ice cream
already 80 cm from the ground



Settaggio e controllo da remoto della vetrina
Showcase's remote setting and control

ORION

PLUS COLLECTION



New look per soddisfare qualsiasi esigenza
New look to meet any needs



Massima visibilità del prodotto esposto
Great visibility of the product



GAS R290 = -99.85% Impatto ambientale
R290 GAS = -99.85% Environmental impact

02

K A T + E

La vetrina refrigerata KATE+ molto di più di una semplice vetrina gelato.

KATE+ è la piccola vetrina di casa Orion in grado di adattarsi a tutti gli spazi a disposizione senza nulla togliere al design e all'eleganza della vetrina.

Linee semplici, spazi ottimizzati e visibilità sul prodotto ottimali fanno di KATE+ la scelta giusta per tutti coloro che hanno bisogno di mostrare al meglio le loro creazioni pur non avendo troppo spazio a disposizione.

Scegli la versione che ti si addice di più, KATE+ è disponibile sia per gelateria che per pasticceria.

KATE+ much more than an ice cream cabinet.

KATE+ is the small Orion display cabinet able to adapt to all the spaces available without detracting from the design and elegance of the cabinet.

Plain lines, reduced spaces and ideal visibility make KATE+ the right choice for all those who need to best show their creations while not having too much space available.

Choose the version that suits you best, KATE+ is available for both ice cream and pastry.



04



06



07



08





12



KATE+ È PLUS ANCHE NEL COLORE

KATE+ IS ALSO PLUS IN THE COLOR

14



BLUE PLUS

GREEN PLUS



RED PLUS



ORANGE PLUS



VIOLET PLUS

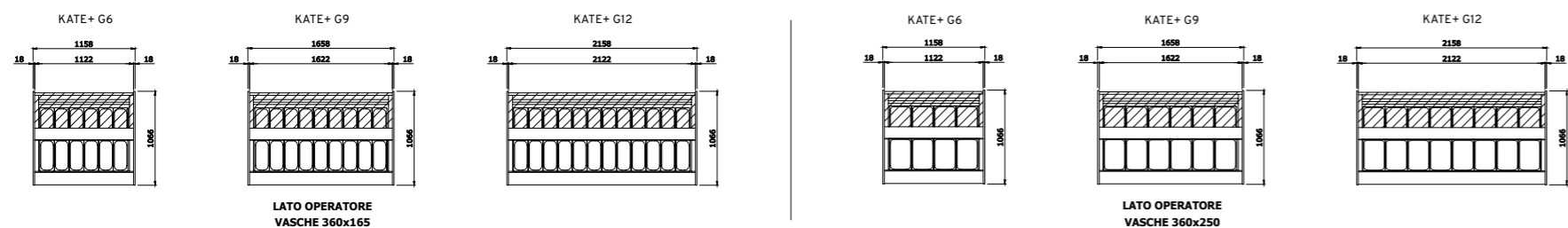
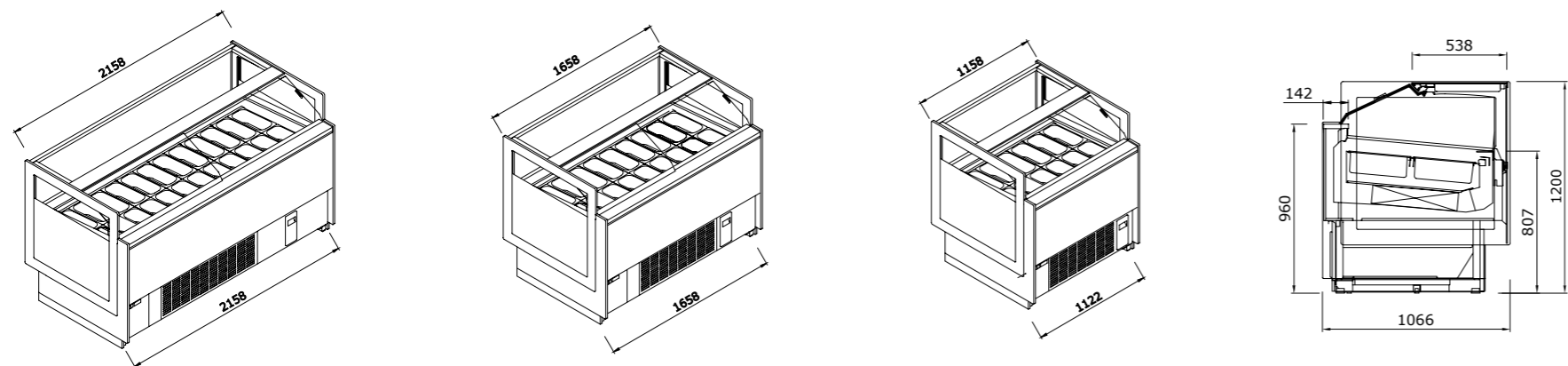

| | GAS | TEMP. ESERCIZIO [°C] WORKING TEMPERATURE | CAP. FRIGO [W] COOLING CAP. | ALIMENTAZIONE V/ph/Hz ELECTRIC SUPPLY V/ph/Hz | POTENZA TOT. [W] MAX POWER INPUT | PESO [Kg] WEIGHT |
|-----|------|---|--------------------------------|--|-------------------------------------|---------------------|
| G6 | R290 | -18/-20 | 935 | 230/1/50 | 940 | 305 |
| G9 | R290 | -18/-20 | 1288 | 230/1/50 | 1400 | 360 |
| G12 | R290 | -18/-20 | 1588 | 230/1/50 | 1811 | 440 |

| | GAS | TEMP. ESERCIZIO [°C] WORKING TEMPERATURE | CAP. FRIGO [W] COOLING CAP. | ALIMENTAZIONE V/ph/Hz ELECTRIC SUPPLY V/ph/Hz | POTENZA TOT. [W] MAX POWER INPUT | PESO [Kg] WEIGHT |
|-----|-------|---|--------------------------------|--|-------------------------------------|---------------------|
| G6 | R452a | -18/-20 | 1550 | 400/3/50 | 1210 | 305 |
| G9 | R452a | -18/-20 | 1750 | 400/3/50 | 1457 | 360 |
| G12 | R452a | -18/-20 | 2160 | 400/3/50 | 1773 | 440 |

STRUTTURA:

- Basamento in tubolare verniciato a polveri epossidiche.
- Vetro frontale monolitico riscaldato apribile verso il basso.
- Spalle in vetro camera colore standard cornice RAL 9001 - interno RAL 9006.
- Plafoniera di illuminazione a LED sul tettino.
- Chiusura posteriore con tendina avvolgente o pannelli scorrevoli.

TECNOLOGIA:

- Quadro comandi del tipo elettronico con termostato e termometro digitale
- Sbrinatorio automatico programmabile.
- Alimentazione elettrica 230V/1ph/50Hz (gelateria e pasticceria) e 400V/3ph/50Hz (gelateria R452a).
- R452a: Unità refrigerante semiermetica interna con condensazione ad aria (optional esterna e ad acqua) con possibilità su richiesta di compressore ermetico (SOLO per unità interna). Sbrinatorio ad inversione di ciclo. Evaporazione automatica dell'acqua di condensa (optional).
- R290: Unità refrigerante ermetica interna con condensazione ad aria. Sbrinatorio ad inversione di ciclo. Evaporazione automatica dell'acqua di condensa (optional).

OPTIONAL:

- Pannello di rivestimento frontale e delle spalle personalizzabile con RAL a scelta.
- Kit Canalizzazione.

CONNETTIVITÀ:

- Sistema di gestione da remoto o tramite APP della vetrina

STRUCTURE:

- Tubular base painted with epoxy powder.
- Monolithic heated front glass that can be opened downward.
- Side panels made of chamber glass. Frame standard color RAL 9001 - Internal part RAL 9006 LED lighting ceiling light on the canopy.
- Rear closure with wraparound curtain or sliding panels.

TECHNOLOGY:

- Electronic control panel with thermostat and digital thermometer
- Automatic programmable defrosting
- Power supply 230V/1ph/50Hz (ice cream and pastry shop) and 400V/3ph/50Hz (ice cream shop R452a)
- R452a: Semi-hermetic indoor refrigeration unit with air condensing (optional outdoor and water condensing) with optional hermetic compressor option (indoor unit ONLY). Reverse cycle defrosting. Automatic evaporation of condensate water (optional)
- R290: Air-cooled indoor hermetic refrigeration unit. Reverse cycle defrosting. Automatic evaporation of condensate water (optional)

OPTION:

- Front cladding panel and side panels customizable with RAL of your choice.
- Ducting Kit.

CONNECTIVITY:

- Remote or app management system of the showcase

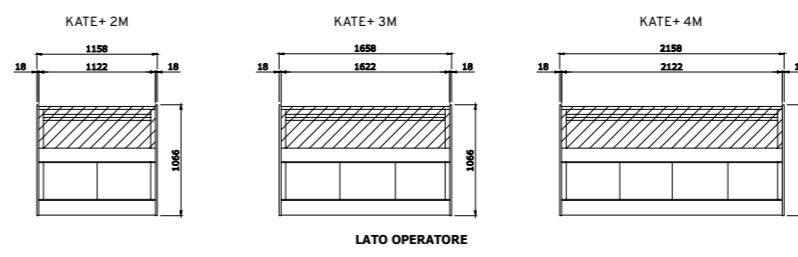
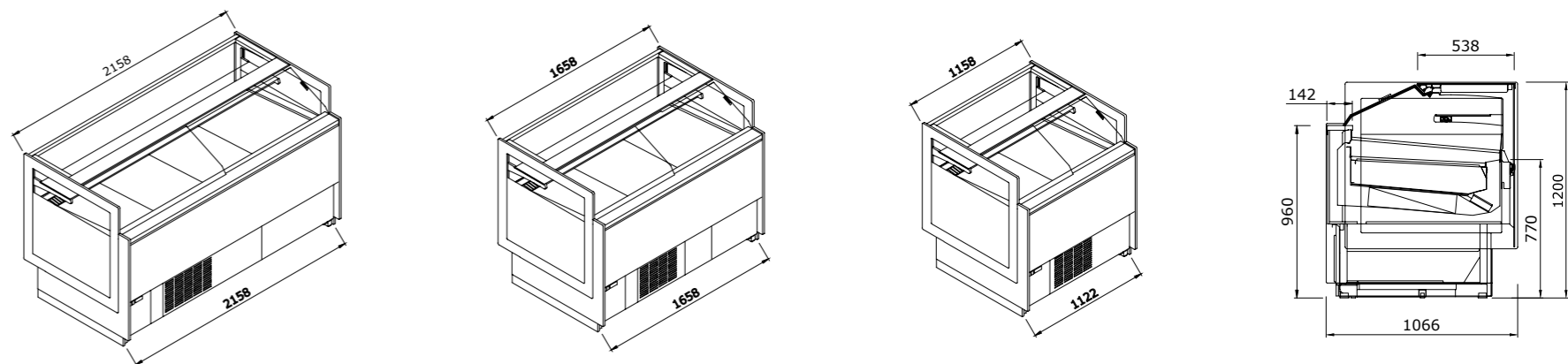

| | GAS | TEMP. ESERCIZIO [°C] WORKING TEMPERATURE | CAP. FRIGO [W] COOLING CAP. | ALIMENTAZIONE V/ph/Hz ELECTRIC SUPPLY V/ph/Hz | POTENZA TOT. [W] MAX POWER INPUT | PESO [Kg] WEIGHT |
|--------|------|---|--------------------------------|--|-------------------------------------|---------------------|
| RVS 2M | R290 | +4/+6 | 1011 | 230/1/50 | 700 | 230 |
| RVS 3M | R290 | +4/+6 | 1383 | 230/1/50 | 924 | 290 |
| RVS 4M | R290 | +4/+6 | 1501 | 230/1/50 | 960 | 330 |

| | GAS | TEMP. ESERCIZIO [°C] WORKING TEMPERATURE | CAP. FRIGO [W] COOLING CAP. | ALIMENTAZIONE V/ph/Hz ELECTRIC SUPPLY V/ph/Hz | POTENZA TOT. [W] MAX POWER INPUT | PESO [Kg] WEIGHT |
|--------|-------|---|--------------------------------|--|-------------------------------------|---------------------|
| RVS 2M | R452a | +4/+6 | 1021 | 230/1/50 | 742 | 210 |
| RVS 3M | R452a | +4/+6 | 1289 | 230/1/50 | 953 | 270 |
| RVS 4M | R452a | +4/+6 | 1625 | 230/1/50 | 1170 | 310 |

STRUTTURA:

- Basamento in tubolare verniciato a polveri epossidiche.
- Vetro frontale monolitico riscaldato apribile verso il basso.
- Spalle in vetro camera colore standard cornice RAL 9001 - interno RAL 9006.
- Plafoniera di illuminazione a LED sul tettino e sulla mensola di esposizione.
- Chiusura posteriore con tendina avvolgente o pannelli scorrevoli.

TECNOLOGIA:

- Quadro comandi del tipo elettronico con termostato e termometro digitale.
- Sbrinatorio automatico a pausa di funzionamento.
- Alimentazione elettrica 230V/1ph/50Hz (pasticceria).
- Unità refrigerante interna con condensazione ad aria (solo per R452a optional esterna e ad acqua). Evaporatore ventilato.

OPTIONAL:

- Pannello di rivestimento frontale e delle spalle personalizzabile con RAL a scelta.
- Kit Canalizzazione.

CONNETTIVITÀ:

- Sistema di gestione da remoto o tramite APP della vetrina

STRUCTURE:

- Tubular base painted with epoxy powder.
- Monolithic heated front glass that can be opened downward.
- Side panels made of chamber glass. Frame standard color RAL 9001 - Internal part RAL 9006.
- LED lighting ceiling light on the canopy and on the display shelf.
- Rear closure with wraparound curtain or sliding panels.

TECHNOLOGY:

- Electronic type control panel with thermostat and digital thermometer.
- Automatic defrosting at operation pause
- Power supply 230V/1ph/50Hz (pastry).
- Air-cooled indoor refrigeration unit. (for R452a optional outdoor and water only). Ventilated evaporator.

OPTION:

- Front cladding panel and side panels customizable with RAL of your choice.
- Ducting Kit.

CONNECTIVITY:

- Remote or app management system of the showcase

Orion si riserva il diritto di apportare modifiche ai prodotti illustrati in questo catalogo, in qualunque momento senza l'obbligo di preavviso.
Le finiture riprodotte in questo catalogo sono indicative per le inevitabili differenze dovute alla riproduzione tipografica.

Orion reserves the right to make modifications to the products shown in this catalogue at any time without prior notice. The finishings shown in this catalogue are approximate, as a printed reproduction causes inevitable colour differences.

© ORION

I prodotti possono essere tutelati da brevetto e/o da design.
Tutti i diritti riservati

Products may be protected by patent and/or design.
All rights reserved.

EDIZIONE APRILE 2024



ORION
VIALE DELL'INDUSTRIA 15
60035 JESI (AN)
ITALY

PHONE: +39 0731 61531
FAX: +39 0731 6153413

INFOWEB@ORIONSTYLE.COM
WWW.ORIONSTYLE.COM



K A
T +
E

www.orionstyle.com

The Orion logo features the word "ORION" in a bold, white, sans-serif font. A thin, white, curved line arches over the letters, starting under the 'O' and ending under the 'N', creating a stylized orbital or swoosh effect.

ORION